

General information

Cavity

Type series: C0830

Dimensions and sectional view

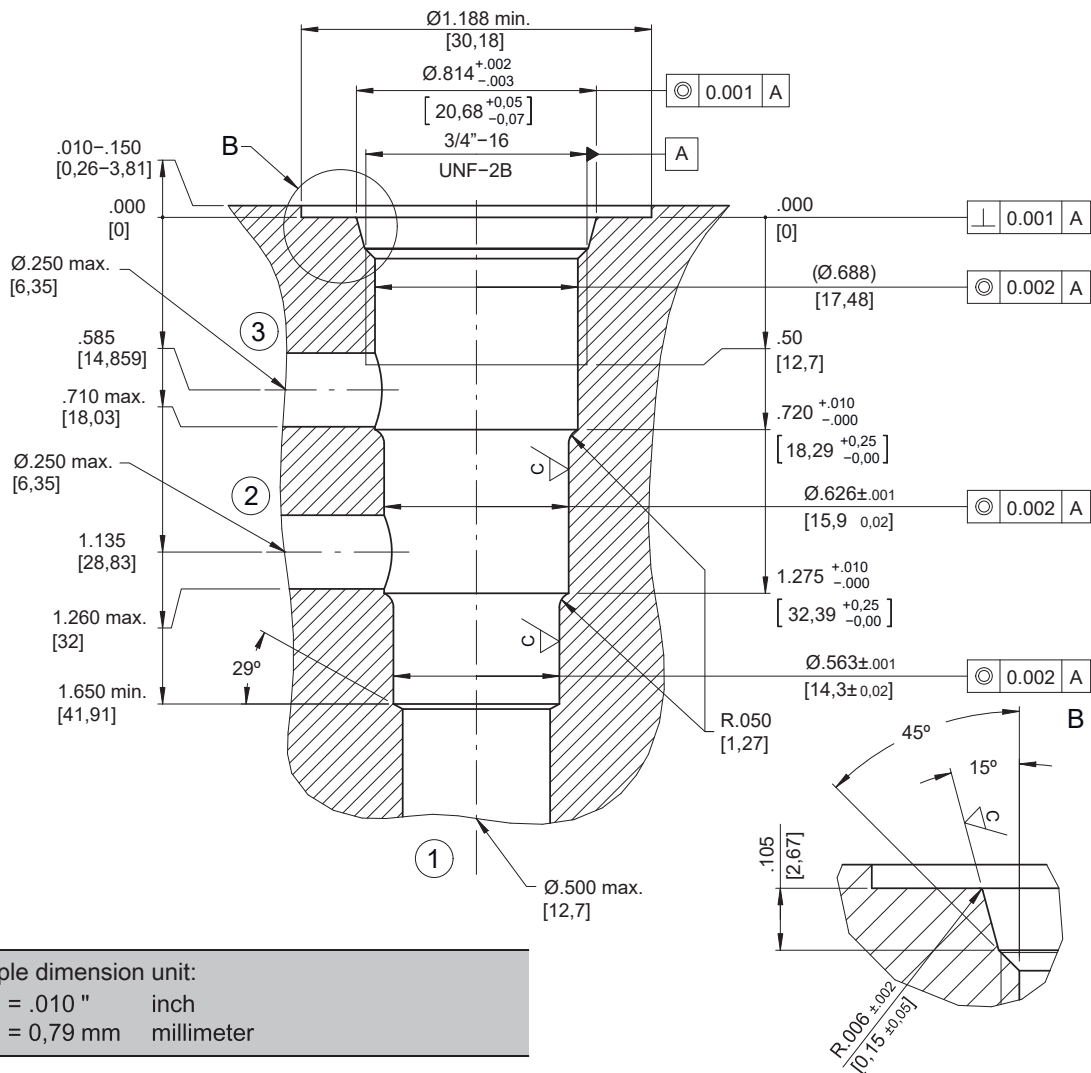

Example dimension unit:

.010 = .010" inch
[0,79] = 0,79 mm millimeter

Dimension Tolerances

Unless otherwise specified

| | |
|--------|---------|
| 0.000 | ± .005" |
| 0.00 | ± .010" |
| Angles | ± 1/2° |

Surface roughness

| | C | D |
|----|---------------------|----------------------------|
| Ra | 45 µin (1.15 µm) | 125 µin (3.2 µm) |
| | D | Unless otherwise specified |

Installation information



ATTENTION!

You must maintain the specified positional and diametral tolerances. To ensure trouble-free operation of the screw-in cartridges, we strongly recommend that pilot drilling, boring, reaming and cavity thread-cutting are always performed in one setup.



NOTE!

Cavity type to factory standard.



NOTE!

We offer form tool sets for sale or hire. See data sheet 520-P-000050 for further information.